

MULTI-GOAL OPTIMIZATION OF A CARRY-MOULD

B. R e g g i a n i¹⁾, F. C o s m i²⁾

¹⁾ **University of Bologna**
Department of Mechanical Engineering
Viale Risorgimento 2, 40136 Bologna, Italy

²⁾ **University of Trieste**
Department of Mechanical Engineering
Via A. Valerio 10, 34127 Trieste, Italy

A common engineering task is the optimization of components that are part of multi-body assemblies, in which it is difficult to extrapolate and define the boundary conditions to be applied for the component optimization. This work presents a procedure for multi-goal optimization of components that are integrated in multipart engineering systems. The efficiency of the procedure is illustrated by means of a test case, a carry-mould that is part of a multi-component blowing machinery. Target goals of the optimization process are the minimization of moment of inertia and of global mass and the maximum allowable displacement in a number of control points.

Key words: design, multi-goal optimization, carry-mould, blow-machinery assembly, FE modelling.

1. INTRODUCTION

The optimum design of mechanical components is the one that best meets all the requirements specified by engineers, resulting to be as effective as possible in terms of their performance and reliability. Due to different reasons, optimization is frequently a difficult task. For instance, in many real problems, attention must be directed not only to minimization of a single function but to optimization of more than one target goal, with simultaneous satisfaction of the predefined constraints placed on the design. Moreover, typical engineering systems are described by a very large number of variables which even the most skilled designers are unable to take simultaneously into account without proper powerful numerical simulation tools. Besides, mechanical components are often a part of complex assemblies, thus making it difficult to extrapolate and define the boundary conditions to be applied in the component for its design optimization.

A procedure for investigation of the multi-goal optimum design of components that are integrated in complex engineering systems is presented in this work.

A carry-mould that is a part of the blowing machinery composed of several components, is used as a test component in order to illustrate the procedure. Target goals of the optimization are the minimization of moment of inertia and global mass of the carry-mould, while the main displacement in a number of control points is imposed to remain under an allowable peak value. Numerical scales and values have been excluded from the results because of confidentiality issues, but this does not affect comprehensibility and relevance of the results.

2. OPTIMIZATION OF THE CARRY-MOULD

The original design of the carry-mould used as a test case to illustrate the proposed procedure is shown in Fig. 1a (base model). Two additional initial parametric geometries of the carry-mould were generated for a computationally efficient investigation of a number of potential designs: the mono-rib model (Fig. 1b) and the two-ribs model (Fig. 1c).

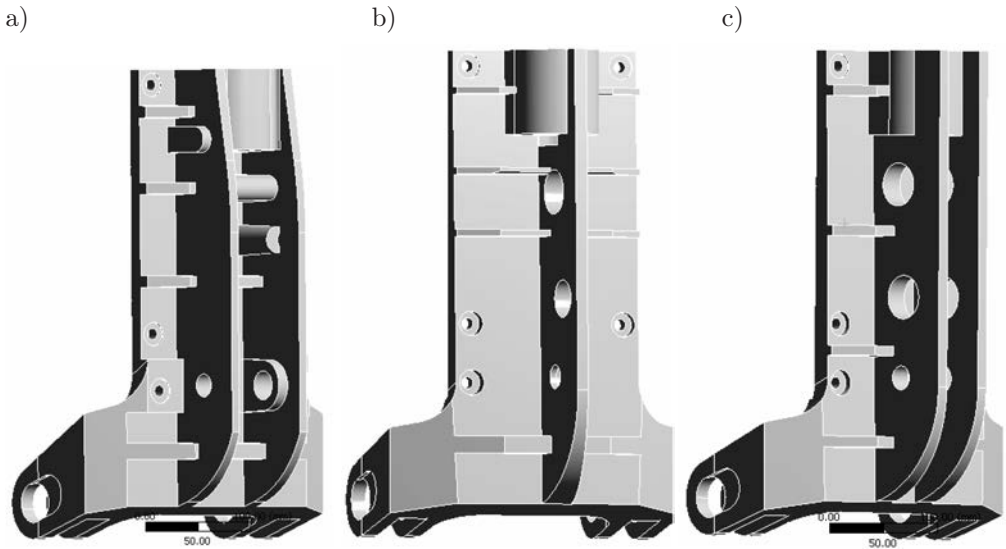

FIG. 1. The initial parametric geometries of the carry-mould: a) the base model, b) the mono-rib model, c) the two-ribs model.

Parameterization of the base model involved the geometric variables that define the external profile of the carry-mould, the width and clearance angles of the rib and ribbings and the thickness around the upper hole. In addition, in the two-ribs and mono-rib models, also two lightening holes were parameterized in position and diameter. A limited number of geometric fixed constraints was imposed in the parameterization (location and diameter of the holes for the pins and position of the contact plate of the carry-mould).

The proposed optimization procedure allows to investigate the design space by the definition of a 3D FE (Finite Element) equivalent single-body model of the component, obtained as explained in the following.

First, a simplified 2D FE model of the blowing machinery was generated from the original 3D CAD model (Fig. 2a). Indeed, evaluation of numerical robustness and accuracy in complex 3D problems is extremely time-consuming and the 2D simplified model allows to identify (with smaller computational requirements) the average element dimension, the most critical contact regions and the proper solution parameters to be used in the component 3D FE model that will constitute the starting point for optimization. The 2D FE model of the assembly was generated by virtually cutting the 3D CAD model along the middle longitudinal cross-section (Fig. 2b) and by using the contour lines of components (Fig. 2c). Boundary conditions applied to the 2D model were analogous to those imposed on the 3D FE model but, in order to replicate the real 3D problem behaviour, the 2D model was also stiffened by constraining appropriate zones of the frame and by adding 2D beam elements with infinite stiffness where appropriate.

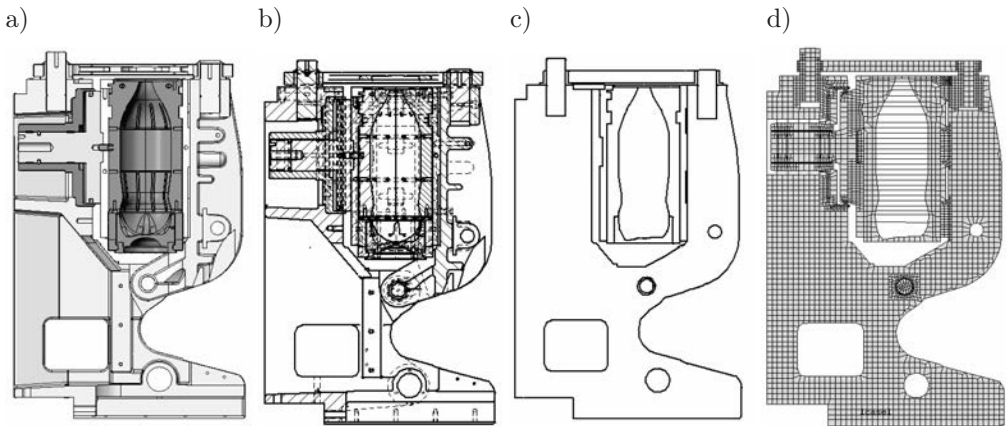

FIG. 2. a) Original 3D CAD model; b) 2D CAD model; c) simplified 2D CAD model; d) optimal 2D FE model.

A 3D FE model of the complete multi-body assembly (24 components) was successively generated in order to identify the values of displacements and contact pressures acting on the carry-mould and constituting the constraints for the successive optimization simulations. The meshed model had 171955 20-nodes tetrahedral elements and 235194 nodes. Boundary conditions applied to the model considered the blowing pressure, a vertical pushing force and the gripping screw forces acting in the real physical system.

Finally, the boundary conditions (displacements and contact pressure) derived by the 3D FE model of the assembly were imposed on the equivalent

single-body model of the carry-mould, by means of a set of purposely created grids of areas and points (Fig. 3).

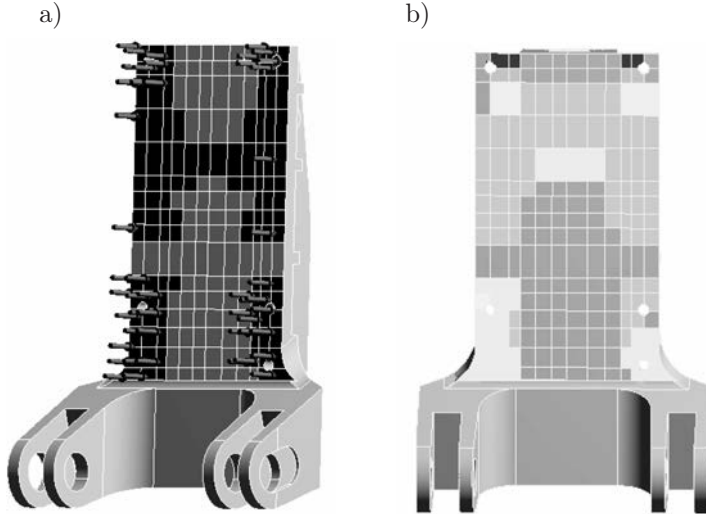

FIG. 3. Qualitative maps of the displacements (a) and contact pressure (b) applied on the carry-mould from the assembly 3D FE model simulation.

ModeFRONTIER MDO (Multi Design Objective) tool [2] was used for the multi-goal optimization of the carry-mould.

By adopting the equivalent single-body model of the examined component [1], the same output values as those obtained from the complete multi-body assembly 3D FE model were found. At the same time, a drastic reduction of the optimization process computing-time was achieved, thus allowing for the evaluation of a very large number of design solutions. In fact, while each complete multi-body assembly 3D FE model simulation required approximately 20 hours, the equivalent single-body model simulation took only 5 minutes. Moreover, the definition of an equivalent single-body model simplified the identification of the entities needed for optimization: the *input variables*, parameterized in the model (that is the geometric variables previously defined for the base, two-ribs and mono-rib models), the *output parameters* that have to be optimized, and the optimization *constraints*. As already mentioned, the target goals were the minimization of moment of inertia and of global mass (output parameters) of the carry-mould. The optimization constraints were applied in a number of control points in the contact plate with the blow-mould shell, where the maximum allowable discrepancy from the values obtained by the 3D FE assembly model was limited to 10%. Results were expressed by a set of feasible non-dominated solutions, the Pareto optimal set (Pareto front). The evolutionary algorithm used to solve the test problem was the Non-dominated Sorting Genetic Algorithm (NSGA-II) implemented in

modeFRONTIER [3, 4]. An initial population of 20 configurations was set in the NSGA-II algorithm for each of the three analysed parametric geometries. Each initial population was identified by a pseudo-random SOBOL DOE sequence, thus reducing the clustering effect in the design space uniform sampling.

Lastly, robustness and stability of each candidate solution were investigated. Uncertainties in manufacturing errors, material properties and applied loads on the equivalent FE single-body model were investigated by means of the Multi-Objective Robust Design Optimization (MORDO) tool in modeFRONTIER. These variables were regarded as Gaussian distributions [5], characterized by a fixed standard deviation of 50 μm for the geometric parameters and a 10% variation of the nominal values for the grid contact pressure. Literature provided reference for uncertainties on the elastic modulus, the Poisson coefficient and the material density [6, 7]. A sensitivity analysis and a convergence test of the target goals standard deviation were performed to establish the number of runs in the robust design routine. The configuration characterized by the lowest standard deviation of the objective functions was then chosen as the final optimum design.

3. RESULTS

From the optimal 2D FE model of the assembly (Fig. 4) it followed that the most critical contact regions, requiring a smaller average elements dimension, were those including upper pins, probably because they were the most responsible for the model kinematics behaviour.

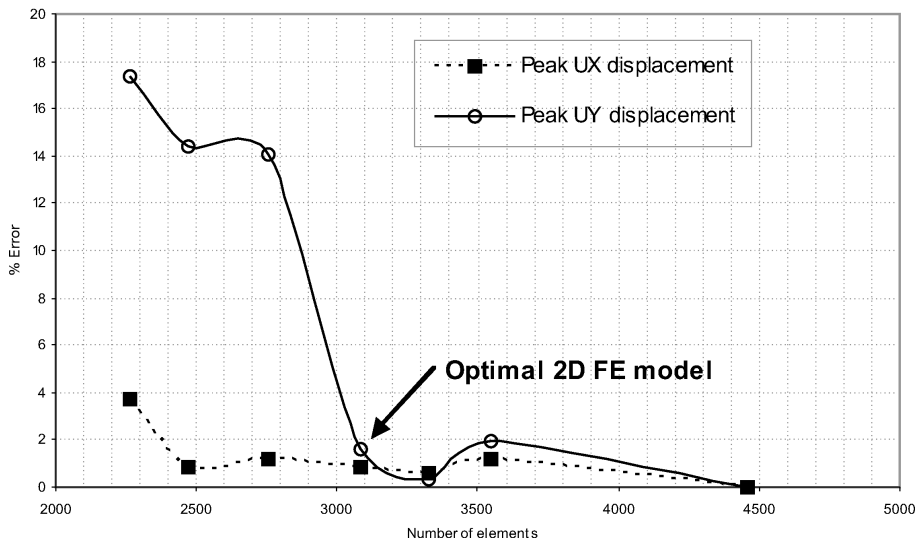

FIG. 4. Percentage error in output displacements with respect to the most refined FE model (assumed as the exact solution) vs the number of elements in the 2D FE model.

The results found for the optimal 2D FE model were used to set the average elements dimension in the 3D FE model of the assembly. A qualitative example of the results predicted by the 3D FE assembly model is shown in Fig. 5.

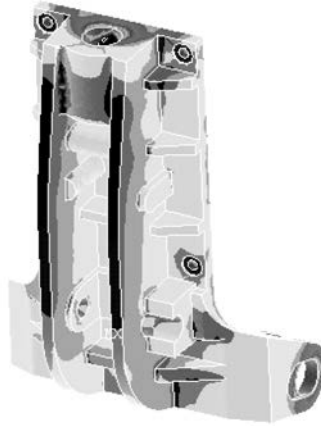

FIG. 5. Qualitative map of Von Mises stress distribution as predicted by the 3D FE model.

The good agreement between the single-body and the 3D assembly FE models outputs is qualitatively shown in Fig. 6.

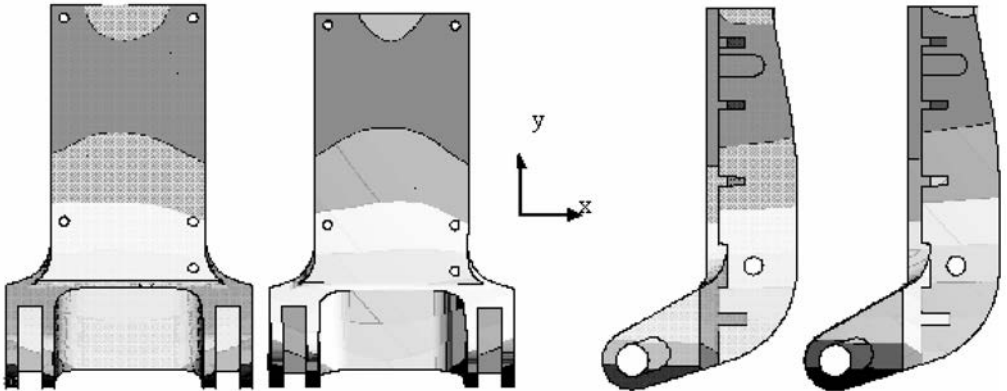

FIG. 6. Comparison of the map of the displacements along the x direction in the 3D FE model (right) and in the single-body model (left) (front and lateral view).

The displacements in a selected set of benchmark points, predicted by the equivalent single-body model, showed an average percentage error of $1.3 \pm 1\%$ with respect to the analogous displacements computed by the 3D FE model of the assembly, indicating a very good agreement between the results.

The optimization procedure gave a total number of 6 solutions to be the candidates for the final optimum design (three for the base model, one for the

mono-rib model and two for the two-ribs model). For each original geometry, these solutions were the designs meeting the highest number of constraints on displacements, with the highest percentage improvement of the output objective functions (Table 1).

Table 1. Best target goals improvements achieved with candidate optimal designs.

Goal (minimization)	% Improvement		
	Base model	Mono-rib model	Two-ribs model
Mass	10.1	4.9	2.5
Moment of inertia	11.4	8.3	5.7

Among these solutions, the design chosen as optimum was the one exhibiting the highest stability, in terms of objective functions, with respect to the uncertainties of the input parameters. Robust design analyses were performed only for the base and two-ribs models, which produced more than one candidate solution.

Among these designs, the base-model candidate solutions were the most stable with respect to uncertainties of the input parameters, being characterized by a lower standard deviation. Thus, the final optimum design was chosen to be the geometric configuration of the base model that showed the highest percentage of improvement in terms of objective functions.

4. CONCLUSIONS

A novel procedure for the multi-goal design optimization of component part of complex assemblies was illustrated in this work by a test case. The opportunity to perform an extensive investigation in the optimum design space constitutes the principal benefit by adopting this procedure. In fact, by defining a 3D equivalent single-body model of the component, a drastic reduction of computation time is achieved without significant loss in the solution accuracy. The impact of uncontrollable variations of variables on design solutions could also be examined by means of the developed methodology. The efficient investigation of the optimization design space allowed to identify and choose the most robust and stable configuration as the final optimum design.

REFERENCES

1. F. COSMI, *A finite element method comparison of wear in two metal-on-metal total hip prostheses*, In the Proceedings of the I MECH E Part H Journal of Engineering in Medicine, **220**, 871–79, 2006.
2. www.esteco.com

3. O. KOKSOY, *Robust design using Pareto-type optimization: A genetic algorithm with arithmetic crossover*, *Computer & Industrial Engineering*, **55**, 208–218, 2008.
4. F. COSMI, *Ottimizzazione multiobiettivo di cambi di velocità per uso automobilistico: progettazione preliminare del gruppo ingranaggi-sincronizzatori-alberi* [in Italian], In Proceedings of the XXVIII AIAS Conference, Vicenza, Italy, 445–58, 1999.
5. C. POLONI, *Multi-objective robust design optimization of an engine crankshaft*, III European Conference on Computation Mechanics Solids, Structures and Coupled Problems in Engineering, Lisbon, Portugal, 2006.
6. UNI EN 1563, *Founding- Spheroidal graphite cast irons* [in Talian], 2004.
7. R.C. JUVINALL, *Fundamental of Machine Component Design*, John Wiley & Sons Inc., 2005.

Received March 23, 2009.
